

1/ Dénudage du fil :

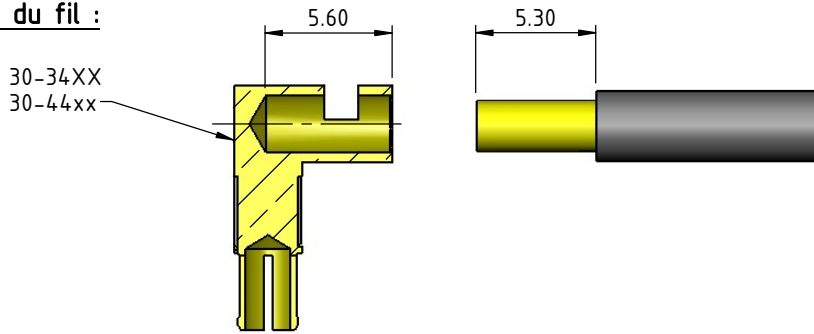

2/ Braser le fil :

- 2.1 - Maintenir le contact dans un support,
- 2.2 - Insérer le fil,
- 2.3 - Chauffer le contact et le fil avec la panne,
- 2.4 - Apporter l'étain.

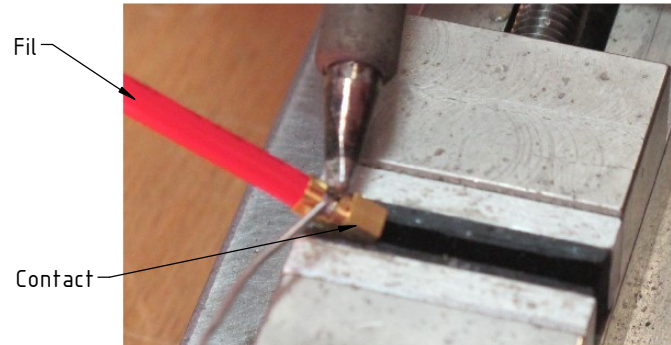

3/ Vérifier la brasure :

- 3.1 - les brins du fil sont recouverts d'étain,
- 3.2 - la brasure est en creux ou affleurante au corps.



4/ Protection de la brasure :

Nous recommandons d'ajouter une gaine thermo-rétractable pour protéger la brasure.

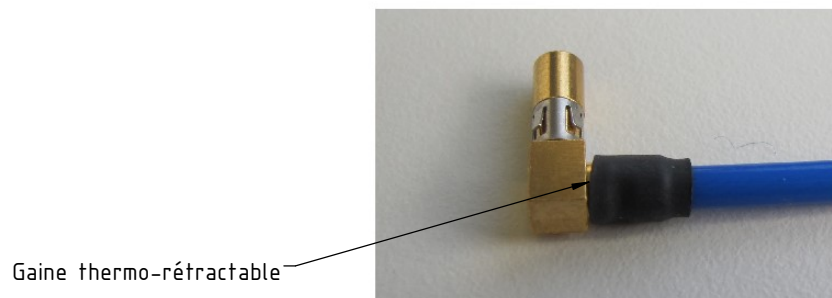

173, rue des fougères Tel. : +33 (0)4.50.36.13.85
Z.I. Les Bracots Fax : +33 (0)4.50.36.11.33
F-74890 Bons-en-Chablais Web : www.nicomatic.com

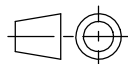

Echelle/Scale

4:1

a	18/04/16	First edition	E.M.		J.R.
Ind.	Date	Modification	Drawn	Checked	Approved
Folder : X:\Méthodes\Documentations\Instruction catalogues\					

Designation : Instruction de câblage contact HP 90°
à braser série 30

Ref : IC30HP04

Page
1/2

A4

1/ Stripping wire :

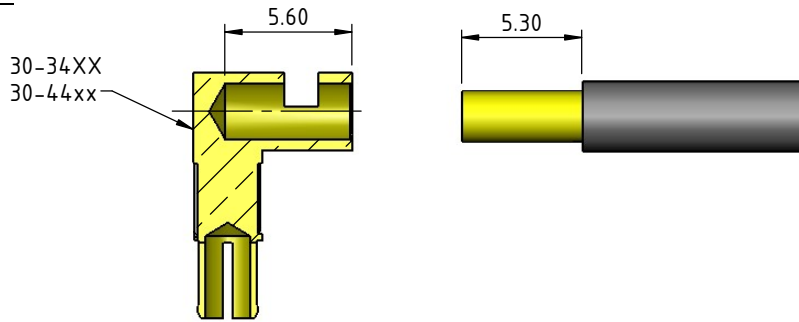

2/ Braze the wire :

- 2.1 - Maintain contact in a carrier,
- 2.2 - Insert the wire ,
- 2.3 - Heat up the contact and the wire with the soldering tip,
- 2.4 - Provide tin.

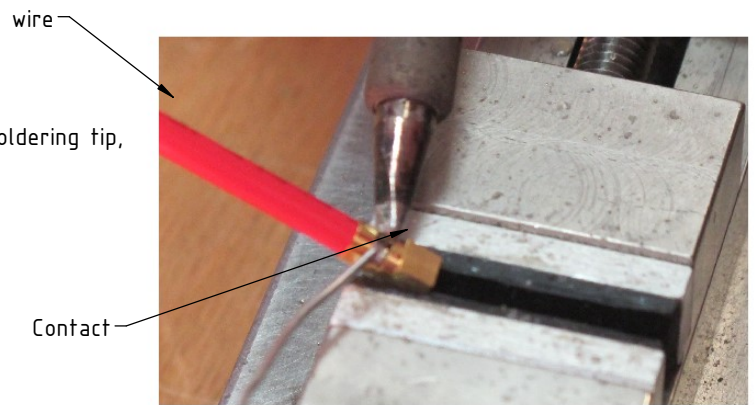

3/ Check the brazing :

- 3.1 - The wire is cover by the tin.,
- 3.2 - the brazing shape is in counter-relief or level with the body.

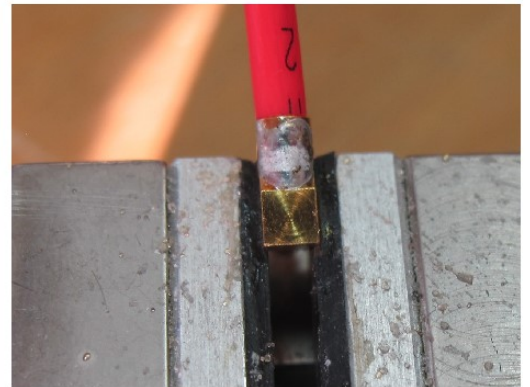

4/ Protection of the braze :

We recommanded to add a heat shrinkable tube to protect the braze.

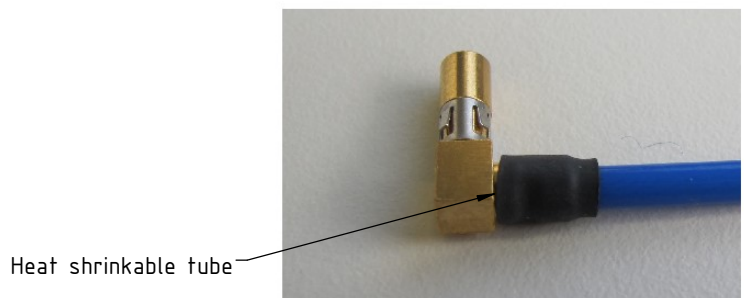

Heat shrinkable tube



173, rue des fougères Tel. : +33 (0)4.50.36.13.85
 Z.I. Les Bracots Fax : +33 (0)4.50.36.11.33
 F-74890 Bons-en-Chablais Web : www.nicomatic.com

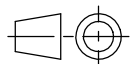

Echelle/Scale
4:1

a	18/04/16	First edition	E.M.		J.R.
Ind.	Date	Modification	Drawn	Checked	Approved

Folder : X:\Méthodes\Documentations\Instruction catalogues\

Designation : Cable instruction for HP 90° contact series 30 to braze

Ref : IC30HP04

Page
2/2

A4